

MODEL 556A
OSCILLOSCOPE
OPERATION MANUAL

本機使用の注意

KIKUSUI ELECTRONICS CORP.

Contents

	<u>Page No.</u>
1. Specifications	2
Outline	2
Specifications	2
2. Operation	5
Power voltage	5
Place of installation	5
Knobs and terminals	5
3. Basic Operating Procedure	10
Measurement of AC voltage	10
Measurement of instantaneous voltage	11
Measurement of phase difference	13
Measurement of frequency	15
4. Maintenance	17
Removal of equipment case	17
Adjustment of DC balance	18
Adjustment of astigmatism	19
Adjustment of vertical axis frequency response	20
Adjustment of sweep balance	21
Horizontal Adjustment of Bright Line	23

I. Specifications

Outline:

Model 556A oscilloscope designed for waveform observation uses a cathode-ray tube with a screen diameter of 133 mm and is highly reliable.

For the vertical axis, a DC/broadband balanced amplifier with a bandwidth of DC~1.5 MHz and a sensitivity higher than 0.02 V/cm is used. For the time base, a 10~100 kHz sweep function and a line sweep function using the power line frequency are provided. To enable external sweep, the horizontal axis amplifier is equipped with an input terminal therefor. The horizontal axis amplifier has a bandwidth of 2 Hz~400 kHz, and a sensitivity higher than $0.3 V_{p-p}/cm$.

Power supply waveform calibration voltage and, terminals for external intensity modulation are also provided.

Specifications:

Vertical axis	Sensitivity	More than 20 mV/cm
	With voltage divider set to 1/10	More than 0.2 V/cm
	With voltage divider set to 1/100	More than 2 V/cm
	With voltage divider set to 1/1000	More than 20 V/cm

Voltage division accuracy Within ± 0.5 dB

Frequency response

AC 2 Hz ~ 1.5 MHz Less than -3dB

DC 0 ~ 1.5 MHz Less than -3dB

Input impedance 1 M Ω Parallel capacity less than 35 pF

Maximum Input Voltage

400 volts DC + AC (1kHz or less). Peak-to-Peak
AC not to exceed 400 volts. at 1/1 range.

600 volts DC + AC (1kHz or less). Peak-to-Peak
AC not to exceed 600 volts. at 1/10, 1/100,
1/1000 range.

Time base

Sweep frequency ranges

(1) TV.H

(2) 10 ~ 100 Hz

(3) 100 Hz ~ 1kHz

(4) 1 kHz ~ 10 kHz

(5) 10 kHz ~ 100 kHz

(6) Line sweep Power line frequency

Finely adjustable continuously within ranges
(1) ~ (5), respectively.

Phase is adjustable with range (6).

Synchronization Internal (+)

External

Power supply

Horizontal axis Sensitivity

More than 0.3Vp-p/cm

Frequency response

2 Hz ~ 400 kHz

Less than -3dB

	Input impedance	Approx. 220 k Ω ; parallel capacity less than 50 pF
	Allowable input voltage	100 V (peak value including DC component)
Calibration voltage	Output	0.05 V _{p-p} and 0.5 V _{p-p} power source waveforms
Power voltage	-----V, 50 or 60 Hz	
	Power consumption	Approx. 40 VA
Dimensions (greatest measurements)	Width	160 mm
	Height	270 mm
	Depth	450 mm
Weight	Approx. 8.5 kg	
Cathode-ray tube	5UPIF	
Acceleration voltage	Approx. 1300 V	
Effective CRT screen area	8 x 10 cm ²	
Intensity modulation		
Accessories	Operation manual	1
	Test record	1

2. Operation

Power voltage:

Although Model 556A operates stably within a primary supply voltage of _____V $\pm 10\%$, it is desirable to operate it at _____V for maintaining the maximum reliability of equipment and a longer life of component parts.

Place of installation:

Avoid installing Model 556A at a dusty place. When using Model 556A near other equipment or machines which generate heat, provide it with an appropriate ventilating means so that Model 556A can operate within an ambient temperature range of $0^{\circ}\text{C} \sim 35^{\circ}\text{C}$. Do not install it near a strong magnetic field or in corrosive gas atmosphere.

Knobs and terminals:

- o INTEN and POWER OFF knob

When this CRT intensity control knob is turned clockwise, the intensity will increase. By rotating the knob full counter-clockwise, power supply will be turned off.

- o FOCUS knob

Used for adjusting the focus of CRT.

- o SYNC SELECT knob

Synchronization is conducted with the power line frequency when this knob is set to the LINE position; with the waveform being observed when set to the INT position; and with the external signal applied to the EXT SYNC terminal when set to the EXT position.

- o SWEEP RANGE switch (black knob)

By operating this sweep frequency selector switch, TV.H, 10 Hz ~ 100 kHz sawtooth wave sweep, LINE SWEEP and EXT HORIZ can be selected. The TV.H position is provided for facilitating observation of waveform at various positions in television receivers. Adjust the red knob so that four waveforms of signal in the vertical system of television receiver can be obtained within a sweep frequency range of 10 ~ 100 Hz, and change over the outside knob to the TV.H position while keeping the red knob where it is, then four waveforms of signal in the horizontal system of television receiver can be observed automatically.

(See Figs. 1 and 2.)

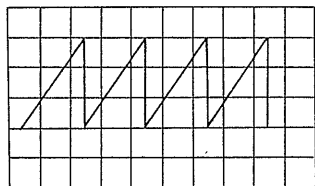

Fig. 1

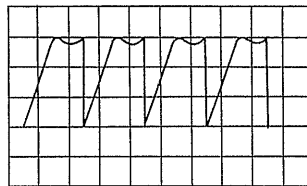

Fig. 2

- EXT HOR terminal
Used for feeding both external synchronizing signal and horizontal axis amplifier output into Model 556A.
- GND terminal
Connected to the panel and chassis.
- VERT SENSITIVITY knob
This voltage divider of the vertical amplifier sets the sensitivity to 1/10, 1/100 and 1/1000. When the knob is set to the CAL 0.5 or 0.05 V_{p-p} position, the voltage for sensitivity calibration is connected to the amplifier inside the equipment and the vertical axis input terminal is disconnected simultaneously. The inner red knob is used for fine adjustment of sensitivity.
- VERT IN and GND terminals
Input to the vertical amplifier is applied to those terminals.
- AC and DC switch
Used for blocking (AC position) and passing (DC position)

the DC component of the waveform being observed.

- o POSITION knob

With the VERT POSITION, the spot on the CRT screen is shifted in the vertical direction; with the HOR POSITION, in the horizontal direction.

- o VERT DC BAL screw

Located at the center of the POSITION knob, this screw is adjusted with a screwdriver for controlling the movement of spot in the vertical direction which occurs when turning the VARIABLE red knob of the VERT SENSITIVITY.

- o EXT INTEN MOD terminals

Located on the rear panel, these terminals are used for intensity modulation of CRT.

- o ASTIG screw

Located on the rear panel, this semi-fixed resistor is used for adjusting the astigmatism of CRT.

- o FUSE holder

Contains a fuse.

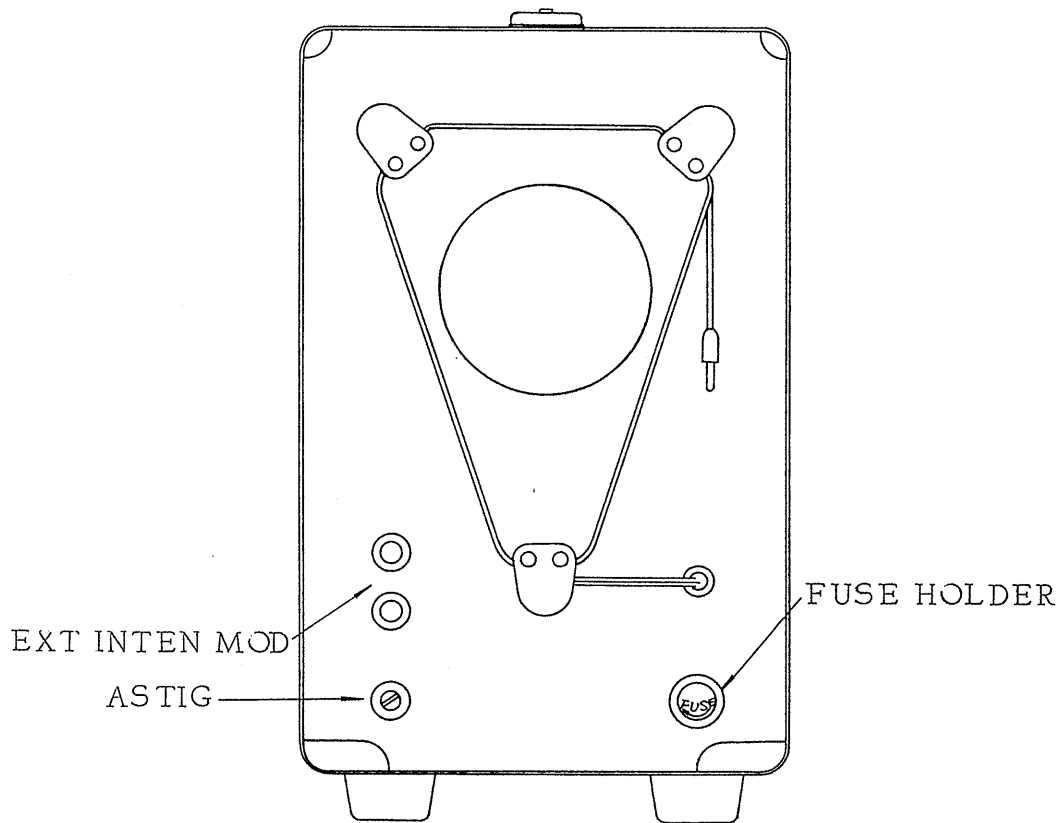

Fig. 3

3. Basic Operating Procedure

Connection of input signals : In the connection between this model and signal source, you had better use a shielded wire. Because if you use conventional sheathed wires, become antenna, and they may contain other signals and noise which they are undesirable not to be carried, you can not watch signals correctly, and synchronization may be disturbed by them.

Measurement of AC voltage : When observing an AC waveform not containing any DC component or the AC component of a waveform having a DC component superimposed, set the vertical input selector switch to the AC position. When observing a waveform containing a DC component, set the switch to the DC position. After calibrating the sensitivity of vertical axis by utilizing the calibration voltage, apply the waveform and read the peak value on the scale graduated on the CRT screen. Or, after observing the waveform, substitute the calibration voltage for the input and read the peak value.

Four sensitivity ranged are available : 1 ~ 1/1000. The sensitivity is continuously variable between ranges by operating the VARIABLE knob. When the sensitivity is set to 0.05 V/cm by using range 1 and the VARIABLE knob, sensitivity at ranges 1 ~ 1/1000 becomes as follows :

RANGE 1	0.05 V/cm
1/10	0.5 V/cm
1/100	5 V/cm
1/1000	50 V/cm

NOTE : While changing over the range after adjusting the sensitivity by using the VARIABLE knob, be careful

not to move this knob accidentally.

When a sine waveform as shown in Fig. 4 is observed, read the vertical amplitude of the waveform in centimeters, and the peak-to-peak voltage can be obtained as follows:

$$\begin{aligned} \text{Voltage} &= (\text{vertical amplitude}) \times (\text{sensitivity of range}) \\ &= 4 \times 0.05 = 0.2 \text{ V}_{\text{p-p}} \end{aligned}$$

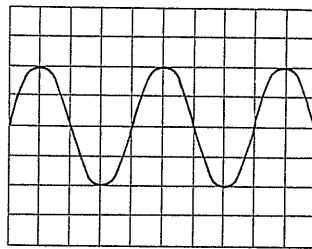

Fig. 4

Measurement of instantaneous voltage:

When measuring the DC level at a desired point of waveform, operate Model 556A as follows:

- (1) Since this measurement involves a DC component, set the vertical input selector switch to the DC position.
- (2) Determine the position of the potential reference line on the screen. When the voltage to be measured is positive to the reference potential, set the trace to the bottommost graduation of the scale on the screen. (The ground potential is normally used as the reference potential. In this

case, connect the vertical axis input terminal to the GND terminal.)

The reference line thus set becomes the reference in DC measurement. Do not move the VERT POSITION knob.

- (3) Apply to the vertical input the voltage to be measured. Read the distance in centimeters from the reference line to the point whose voltage is to be measured. The voltage at that point can be obtained as follows:

$$\text{Instantaneous voltage} = (\text{vertical amplitude from the reference line}) \times (\text{sensitivity of range})$$

The polarity of the measured voltage is positive if the point is above the reference line, and negative if below the reference line.

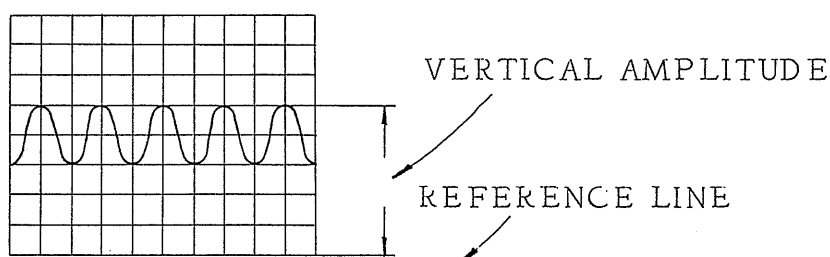

Fig. 5

Measurement of phase difference:

The phase difference between two signals of the same frequency is measured by utilizing a Lissajous' figure. Conduct this measurement after measuring the intrinsic phase difference, since the phase difference between the vertical and horizontal amplifiers of the oscilloscope itself is sometimes not negligible, depending on the frequency of signals to be measured.

- (1) Set the SWEEP RANGE switch to the EXT position. Apply to the vertical input terminal and EXT HORIZ IN terminal the sine wave output of a low-frequency oscillator as shown in Fig. 6, and measure the intrinsic phase difference of the oscilloscope.
- (2) Adjust the SENSITIVITY switch, VARIABLE knob and AMPLITUDE knob for an appropriate size of pattern on the screen as shown in Fig. 4. Vary the frequency of the low-frequency oscillator. The phase difference between the vertical and horizontal amplifiers appears when a loop as shown in Fig. 7 is observed at a frequency higher than several kilohertz. The phase difference is read from the pattern as follows:

Set the horizontal and vertical amplitudes to the scale, measure A and B, then

$$\text{Phase angle } \theta = \sin^{-1} \frac{B}{A}$$

This procedure is applied to measurement of the phase difference between input and output of an amplifier, etc., as shown in Fig. 8. The real phase difference will be the intrinsic phase angle of amplifier subtracted from the measured phase angle θ .

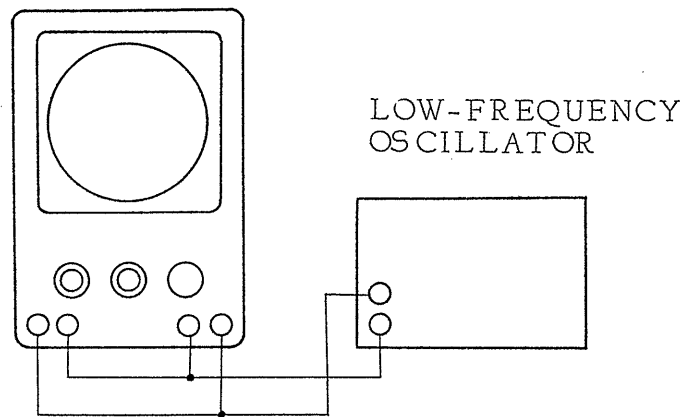

Fig. 6

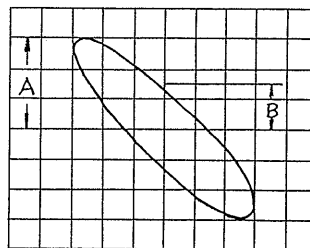

Fig. 7

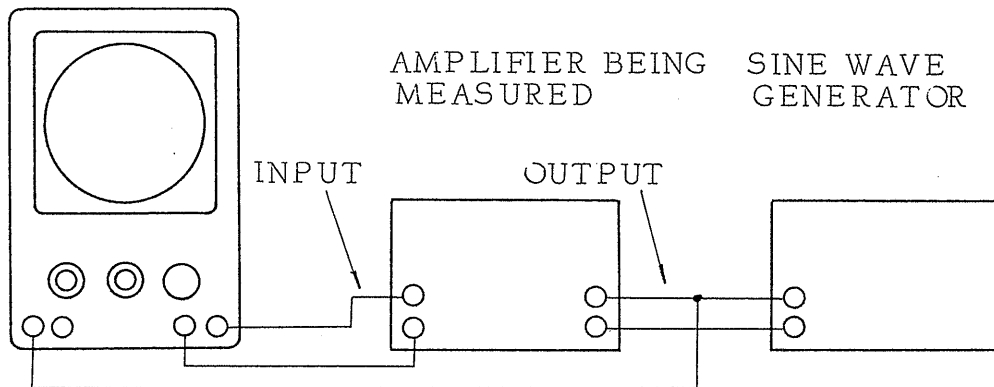

Fig. 8

Measurement of frequency:

When two AC voltages are simultaneously applied to the vertical and horizontal axes, a Lissajous' figure is obtained on the CRT screen. By using this figure and a known frequency as the reference, the unknown frequency of a signal can be measured.

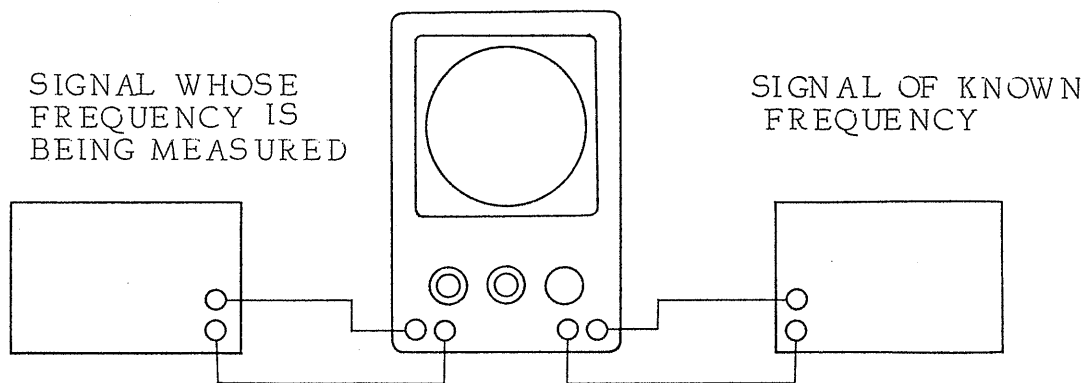

Fig. 9

When the ratio of vertical frequency to horizontal frequency is an integral ratio, the figure will be still as shown in Fig. 10.

From the figure, obtain

No. of loops in contact with vertical tangent: N_v

No. of loops in contact with horizontal tangent: N_h

and the vertical and horizontal input frequencies f_v and f_h can be obtained from

$$\frac{f_v}{f_h} = \frac{N_h}{N_v}$$

Since N_v and N_h may be two in value, respectively, as shown in Fig. 10 depending on the phase relationship between the two signals, be careful to count their correct numbers.

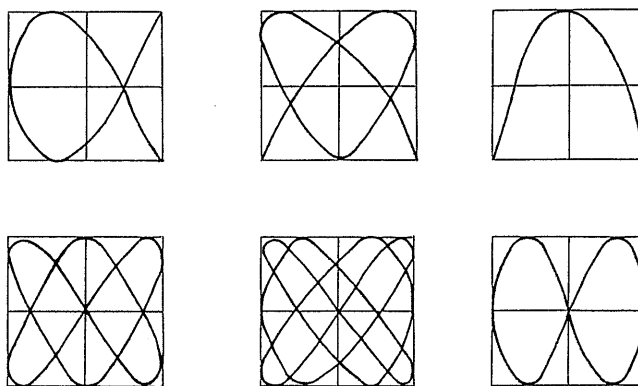

Fig. 10

$$\frac{f_v}{f_h} = \frac{3}{2}$$

$$\frac{f_v}{f_h} = \frac{4}{3}$$

$$\frac{f_v}{f_h} = \frac{2}{1}$$

4. Maintenance

Removal of equipment case:

Take off one screw from the bottom of the case and four screws from the sides of the case as shown in Fig. 11, disassemble the case and sub-panel, and gently draw out the chassis.

Be sure to conduct the above work after turning off power supply since a high voltage is applied in the case. After removing the screws, set the equipment to the normal operating position before drawing out the chassis from the case.

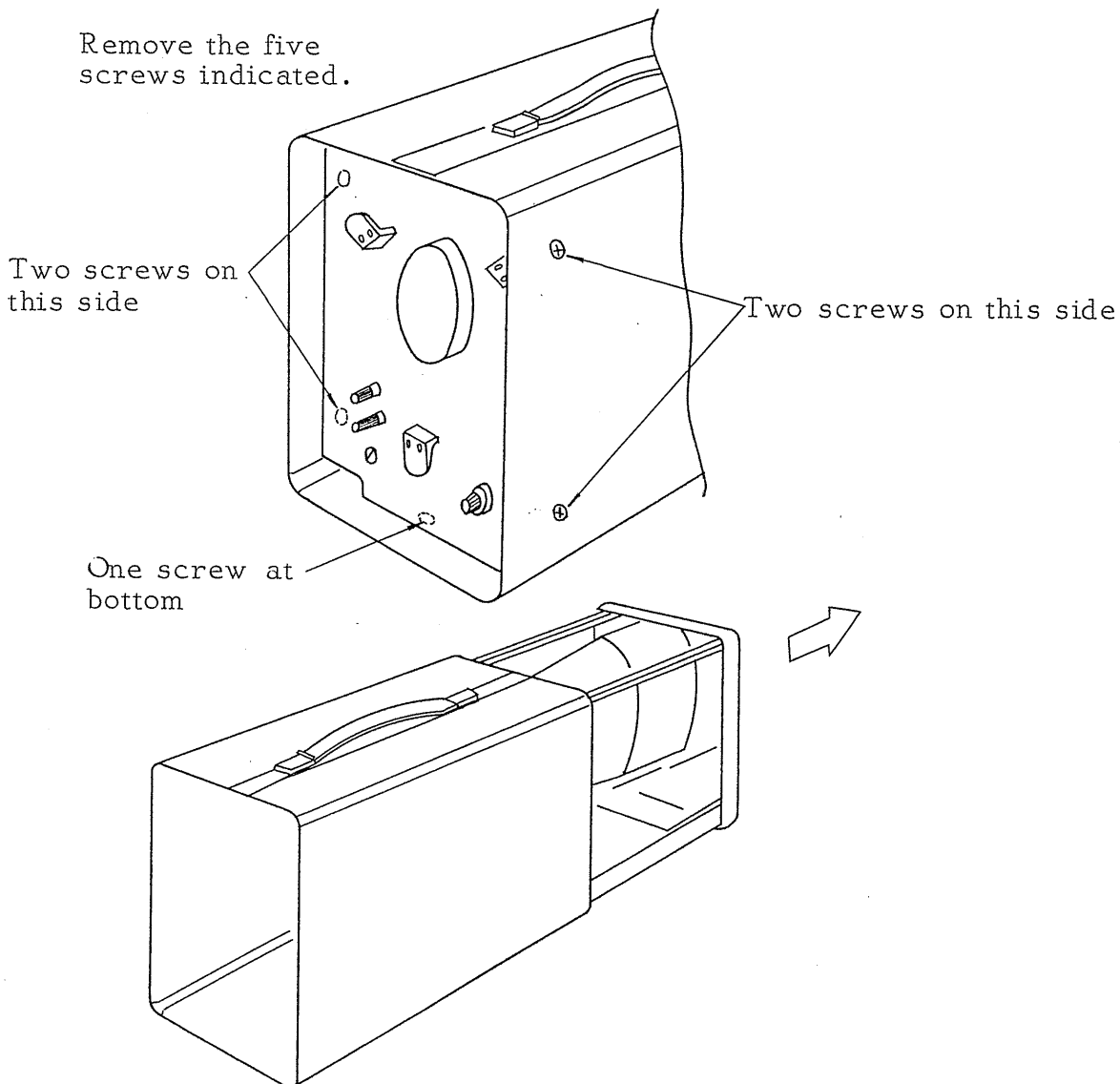

Fig. 11

Adjustment of vertical axis DC balance:

Conduct this adjustment 20 minutes after power supply is turned on, as follows:

- (1) Short the vertical axis input terminal and GND terminal.
- (2) Turn the VERT POSITION knob to set the trace to the center of the scale on the CRT screen.
- (3) Turn the SENSITIVITY VARIABLE knob. If the trace moves upward or downward when the knob is rotated, gradually turn the DC BAL screw and set it where the trace will not move even when the VARIABLE knob is rotated. Since the trace moves upward or downward when the DC BAL screw is turned, set the trace to the center of the scale by using the POSITION knob every time the DC BAL screw is turned.

The DC BAL screw is located at the center of the VERT POSITION knob. Adjust it by using a screwdriver.

Adjustment of horizontal axis DC balance:

Conduct this adjustment 20 minutes after power supply is turned on, as follows:

- (1) Short the horizontal axis input terminal and GND terminal.
- (2) Set the SWEEP RANGE switch to the EXT position.
- (3) Turn the HOR POSITION knob to set the spot to the center of the scale.

- (4) If the spot moves rightward or leftward when the AMPLITUDE knob is turned, rotate the DC BAL screw so that the spot may not move.

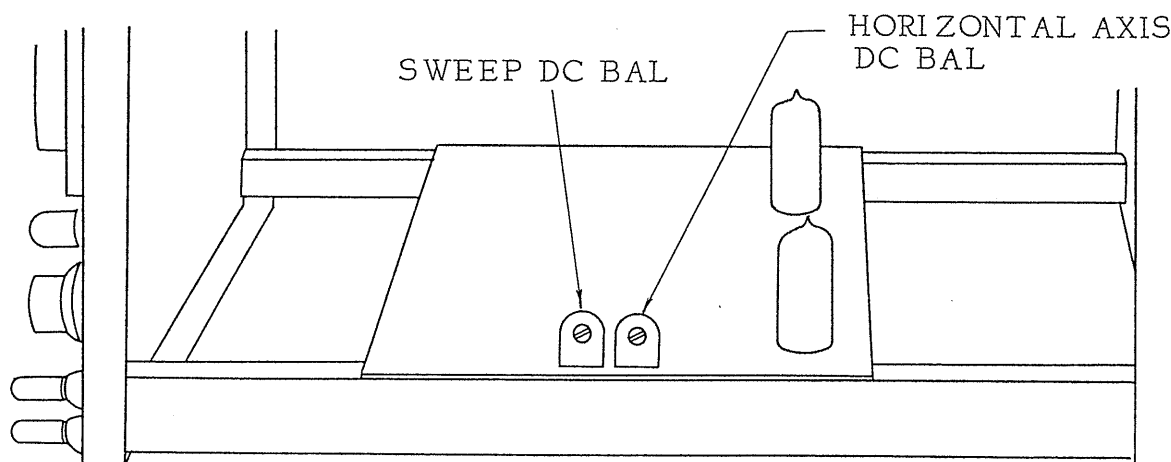

Fig. 12

Adjustment of astigmatism:

The semi-fixed resistor for this adjustment is located as shown in Fig. 13.

- (1) Feed a sine wave signal to Model 556A and let the oscilloscope show the waveform over the full scale.
- (2) Adjust the astigmatism control resistor and the FOCUS knob so that the entire trace may have a uniform thickness.

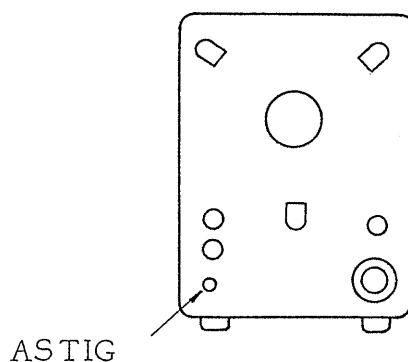

Fig. 13

Adjustment of vertical axis frequency response:

Adjust the frequency response for each range of the voltage divider, as follows:

- (1) Connect to the vertical axis input terminal an accurate square-wave generator having a repetition frequency of approximately 1 kHz and an output voltage range covering 0.05~100 V.
- (2) Set the SENSITIVITY switch to the 1/10 position.
- (3) Adjust the output of the square-wave generator to show one of the square waveforms as shown in Fig. 14 on the CRT screen.
- (4) Adjust semi-fixed capacitor C102 for the waveform as shown in Fig. 14B.

- (5) Follow the above procedure with the SENSITIVITY switch set to the 1/100 and 1/1000 positions and by using the semi-fixed capacitors C104 and C106, respectively.

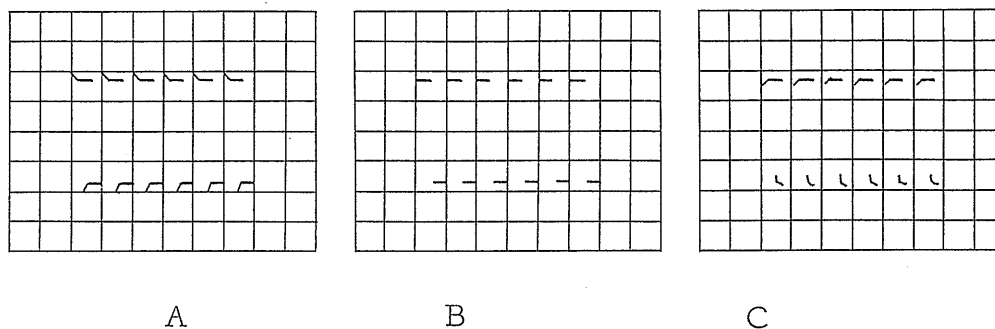

Fig. 14

Adjustment of sweep balance:

Adjust the horizontal axis DC balance as described above, before adjusting the sweep balance as follows:

- (1) Set the SWEEP RANGE switch to the EXT position to stop the internal sweep, and set the spot on the CRT screen to the center of the scale.
- (2) Reset the SWEEP RANGE switch to the 100 Hz ~1 kHz range position. Do not move the HOR POSITION knob thereafter.
- (3) Set the SWEEP RANGE VARIABLE knob to a middle position.

- (4) Set the SYNC SELECT switch to the EXT position.
- (5) Set the trace to the center of the scale by adjusting the SWEEP DC BAL controlling semi-fixed resistor shown in Fig. 12.

NOTE: 1. When the frequency is varied within the sweep range, the trace position moves slightly rightward or leftward. This is not a faulty operation.

2. When the amplitude of the waveform being observed or its repetition frequency is varied, the length of trace changes a little. This is not a faulty operation.